

# 成形机



日本伽利亚工业  
成形机  
目录

## [规格 Specification]

型号 Model	S-201	S-201H
Type	台式 Table-top Type	立式 Standing Type
成形模具尺寸 (mm) Drum Measurement (mm)	φ200×140mm	
成形能力 (个/每小时) Production Output (pcs/h)	360~3640	
成形最大尺寸 (mm) Maximum Formation Size (mm)	114×100 (椭圆形) (Oval Shape)	
成形厚度 (mm) ※ Formation Thickness (mm)	8~26.5	
成形模具刮刀 Drum Scraper	自动循环式 Automatic Circulating	
容器容量 (ℓ) Hopper Capacity (ℓ)	22 ℓ	
传送带 (mm) Conveyor (mm)	L:430mm	
动力 (kW) [A] Motor (kW) [A]	3相200V 0.75 kW [20A] (Three-Phase)	
机器尺寸 (mm) Dimensions (mm)	W761×D457×H680mm	W761×D457×H1207mm
机器重量 (kg) Machine Weight (kg)	100kg	110kg

※最大成形厚度是根据成形尺寸与原料不同  
※The thickness of the formation differs according to size and material used.

## [外形图 Dimensions] S-201

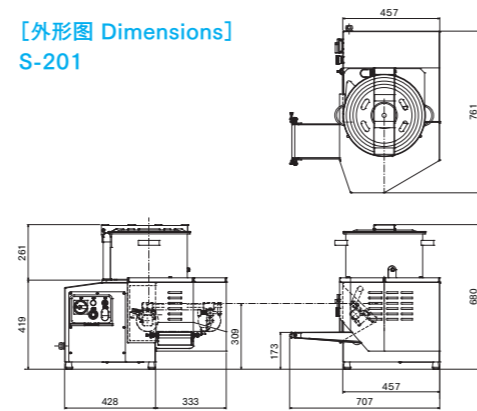

## S-201H

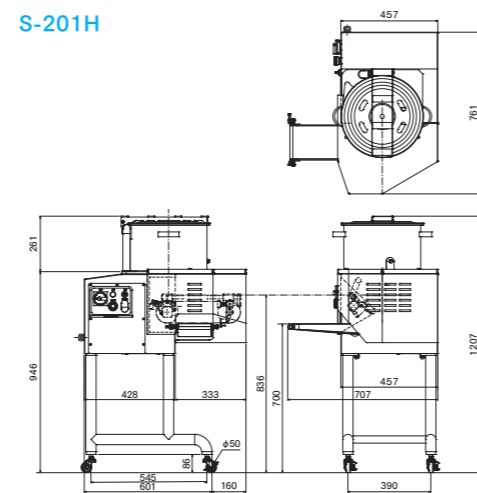

## [S-201标准成形尺寸] Standard Cavity Size for S-201 models

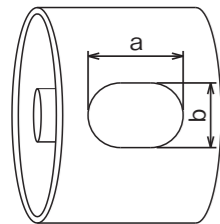

标准成形模具示意图  
Standard Drum Diagram

Type	尺寸 (a×b) Size (a × b)	成形重量 (g) Formation Weight (g) (比重:1) Specific Gravity:1
A Type	75×50	26~86
B Type	75×55	28~87
C Type	95×57	38~118
D Type	95×75	48~125
S Type	85×57	34~104

注1): 成形重量是根据成形尺寸与原料不同  
注2): 关于其他形状请咨询我们  
\*1. The weight of the formation differs according to the size of the formation and the material used.  
\*2. Please contact us for customized shape requests.

## [选购圆形成形模具] Optional Round Drum Variations

成形模具型号 Drum Type	型号 Model	S-201
独立式 Independent Type	2个○○ Dual Cavity	φ37~50mm
	3个○○○ Triple Cavity	φ30~36mm



FOOD FORMER  
成形机  
S-201

挑战「完美」  
Challenging "Perfection"  
株式会社日本伽利亚工业  
NIPPON CAREER INDUSTRY CO., LTD.

代理商 Agent:

邮编791-8043 日本爱媛县松山市东垣生町980-5  
Tel:+81-89-973-6311 Fax:+81-89-973-6353  
980-5 Higashihabu-cho, Matsuyama-city, Ehime, 791-8043, JAPAN  
Tel:+81-89-973-6311 Fax:+81-89-973-6353

E-mail: eigyoun@nippon-career.co.jp http://www.nippon-career.co.jp 为了制品的改良有可能在没有事先预告的情况下进行变更, 敬请谅解。

Ver.2022.08

FOOD FORMER

# 低价格紧凑设计的台式成形机

## Low-cost, Compact, Table-top Food Former

提高成形效率的食品成形机。 A Food Former with Improved Food Forming Efficiency.

Food Former

### Model S-201

台式 Table-top Type

### Model S-201H

立式 Standing Type



Model S-201  
(台式)  
Model S-201  
(table top model)

### 适合成形小型到大型的汉堡肉饼

也可以成形汉堡饼, 肉丸子, 炸丸子  
面点, 鱼肉馅等

[Applications]

### Perfect for hamburgers (small to large size)

As well as deep-fried meat cakes, meat balls, croquettes, fried tofu fritters, fried tofu bites, fried fish cakes, fish paste triangles, and other ground food products

● 也可作为定量填充机使用

Can also be used to fill with pre-determined amounts

Model S-201H  
(立式)  
Model S-201H  
(Standing Type)



### S-201の特長 Features on S-201

- 内置驱动部的一体成形机
- 传送带为标准装备
- 各安全盖装有感应器
- 装有紧急停止按钮
- 可对应树脂模具
- 成形模具可做成2个或3个独立的形状 (选购品)
- Integrated model(internal drive)
- Standard unit comes with conveyor belt
- Includes safety cover equipped with sensor (hopper cover, front cover)
- Emergency stop button
- Resin drum option available
- Independent formation of dual or triple cavity drums is possible (optional)

### 出色的可清洁性 Excellent washability



Model S-201H

拆分后的本体  
Main Unit  
(after disassembly)

拆分后的部件  
Parts  
(after disassembly)

### 对应各种用途的成形模具

Forming Drums Tailored to a Specific Use

-  订制形状模具 (星形, 叶形, 鱼形等各种各样)  
Customized (Atypical) Drum
-  钢丝线切割式 2个型模具  
Independent Dual Round Cavity Drums
-  钢丝线切割式 3个型模具  
Independent Triple Round Cavity Drums
-  树脂模具  
Resin Drum

### 自动循环刮板

Automatic circulating drum scraper

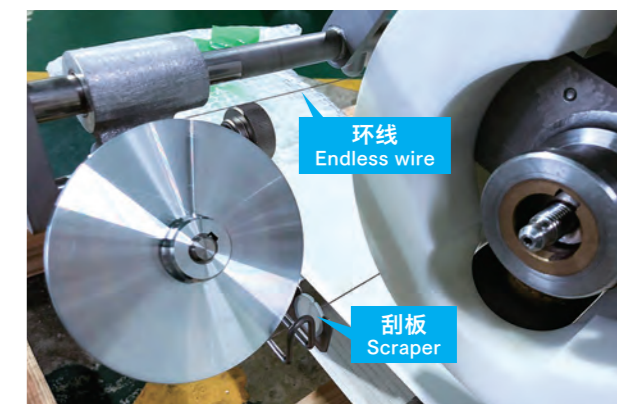

环形导线围绕并与鼓中形成的材料分开。电线上的残留物将被刮板清除, 以便电线可以保持清洁  
Endless wire goes around and separates formed materials from the drum. Residues on the wire will be removed by the scraper so the wire can keep clean.